

WHITEWATER TOWNSHIP
PARKS AND RECREATION ADVISORY COMMITTEE
AGENDA FOR REGULAR MEETING
June 18, 2024
7:00 PM, Whitewater Township Hall
5777 Vinton Road, Williamsburg, MI 49690
Phone 231-267-5141/Fax 231-267-9020

Topic: Parks and Rec Advisory Committee Meeting

Time: June 18, 2024, 07:00 PM Eastern Time (US and Canada)

1. Roll Call of Committee Members
2. Set/Adjust Meeting Agenda
3. Declaration of Conflict of Interest
4. **Public Comment:** Any person shall be permitted to address a meeting of the committee. Public comments shall be carried out in accordance with the following rules and procedures:
 - a. Comments shall be directed to the Committee, with questions directed to the Chair.
 - b. Any person wishing to address the Committee shall speak from the lectern and state his/her name and address.
 - c. Persons may address the commission on matters that are relevant to township Parks and recreation issues.
 - d. No person shall be allowed to speak more than once on the same matter, excluding the time needed to answer Committee members' questions.
 - e. Public comment shall be limited to 3 minutes.
5. Approval of May 21,2024 regular meeting minutes
6. Correspondence/Reports/Presentations:
 - a. PROJECTS; <https://docs.google.com/spreadsheets/d/1Z-s62J-AOq0hWf1JiR9a39dUdwPG8bIUUqwD3AvHeQg/edit#gid=634347005>
 - b. LRNT Project Tracking:
<https://docs.google.com/spreadsheets/d/1CtPq9WqkOFIQMe5mxJ6teRNyOXZwvj1qbUUacCyNgDo/edit#gid=1161341563>
 - c. 2024/25 PRAC Ongoing Projects / Timelines:
https://docs.google.com/spreadsheets/d/1jA_DBOOmX_jPhRQn9OZSjCGD0goiF0wiF0c_oPWzzY/edit#gid=0
7. Unfinished Business:
 - 1) Bylaw Revisions; ON Hold pending Liaison Request
 - 2) WWT Park Playground Toddler equipment – engineering layout drawing – re-review model selection
 - 3) Lossie Road Motorized vehicle access; memo to board – not on their May or June agenda
 - 4) Written 12 month goals / Timelines - finish
8. New Business:
 - 1) LRNT Improvement Project; Gosling engineering concept and estimate
9. Next Meeting July 16, 2024
10. Public Comment
11. Adjournment

Whitewater Township will provide necessary reasonable auxiliary aids and services to individuals with disabilities who are planning to attend. Contact the township clerk at 231-267-5141 or the TDD at 800-649-

DRAFT
Whitewater Township
Parks and Recreation Advisory Committee
Minutes for Regular Meeting
May 21, 2024

Call to order 7:00 p.m.

Roll Call: Melton, Hubbell, Voice, Buczkowski

Absent: Butler, Cosgrove

Also present: Recording Secretary MacLean

Set / Approve Agenda: Set

Declaration of Conflict of Interest: None

Public Comment: None

Approval of minutes:

MOTION by Buczkowski, second by Voice to approve April 16, 2024, meeting minutes.

On voice vote, all in favor. Motion carried.

Reports/Presentations/Announcements/Comments/Correspondence: Email from Kevin Krogulecki of GoslingCzubak as part of unfinished business #3.

Unfinished Business:

1. Bylaw revisions on hold pending liaison request. The liaison request did not make it on the Board agenda.
2. Whitewater Township Park (WTP) toddler equipment engineering layout drawing final review, plus 2% grant and send to Board for approval. Discussion regarding grant.
Discussion of motions to the board for funding and procurement of equipment.

3. Lossie Road, LRNT motorized vehicle access memo to board, was not included on the Township Board May agenda. Lossie Road was not abandoned it was relinquished to the township. They have two very different meanings and consequences.

Memo / email from Kevin Krogulecki of GoslingCzubak:

There is language in the ARPA regarding natural trails and ADA compliance. According to the ARPA language it is not required to be ADA. Discussion of ADA compliance of the boardwalk and bridge so compliance would be met if the rest of the natural trail would be made ADA compliant in the future.

Wetland area needs to be delineated. GT Regional Land Conservancy and GT Conservation District indicated that they did not believe there was going to be a lot of wetland issues but that would be determined by the engineer.

Walking trail, no need for ATV access on the bridge and boardwalk if it does not fit within the budget.

New Business:

1. Final 2024/2025 Budget – review of Park and Rec funds budget
2. Written 12 month goals – timelines
Add a project for discussion making each park and various elements ADA compliant. What? How? Funding?
Feasibility of developing Petobego kayak launch and trail.

Committee Comment and Discussion: None

Next regular meeting: June 18, 2024

Public Comment: None

Adjournment at 9:15

Respectfully submitted,
Lois MacLean
Recording Secretary

MEMO

TO: WWT PRAC Members

FROM: Melissa Melton / Gary Buczkowski

DATE: June 5, 2024

RE: Recreation Capital Projects list and associated work timing schedule

BACKGROUND: At the May PRAC meeting discussion centered around potential capital recreation improvement projects that the committee is interested in pursuing over the next 3-5 years. It was agreed that it would be helpful to establish a timetable of events necessary to complete each of the projects. This document would also help communicate to the Board what the committees' priorities are and the proposed timing.

IMPLICATIONS: Attached is a revised excel spreadsheet with the recently discussed list on the first TAB. The other TABs are related to each of the projects and include a proposed sequence of events and or work items necessary to complete that project.

Should the PRAC come to consensus on this list it will help the process of accomplishing desired projects in the short term and could serve as the foundation for future public discussion in preparation of the Communities next 5 year Master Plan.

RECOMMENDATION: The PRAC should discuss the information provided in the excel spreadsheet base on:

1. Are all desired known projects listed?
2. Are the projects prioritized correctly? (Time based / Yearly) On the All Projects Tab?
3. Are the budget numbers associated with each project realistic?
4. Are some of the projects listed out of the PRAC's Responsibility?



Mel Melton <mammelton@gmail.com>

Lossie Trail update

Kevin S. Krogulecki <kskrogulecki@goslingczubak.com>

Tue, Jun 11, 2024 at 12:20 AM

To: Mel Melton <mammelton@gmail.com>

Hi Mel please see attached updated plan with cost estimate for the lowland trail fill and boardwalk. I reduced the scope to just the lowland (assumed wetland areas) with fill and aggregate trail areas that are still 6' wide with non-ada aggregate. The construction subtotal cost are a little higher than the project budget but reflect more typical construction costs we are seeing. I know the original cost estimate was based on numbers provided by the conservation district, so maybe their potential future bid would be less than my estimate, though I believe this project would need to be publicly bid their involvement would be optional but I'm sure desired. I've been on their boardwalk and natural area structures and I believe they could achieve the project here.

Beyond the construction subtotal are contingency (10%), and engineering which would be necessary for plan/bid document development, contracts, and EGLE permitting (we would make contractor submit for any building department permits as part of their price). This estimate does not include any improvements to the parking area or to the trails in-between improved trail sections within lowlands.

Please take a look and let me know if you have any questions, thanks!

[Quoted text hidden]

 **2023634001.00 C-Concept Lossie Trail DRAFT 061024.pdf**
1262K

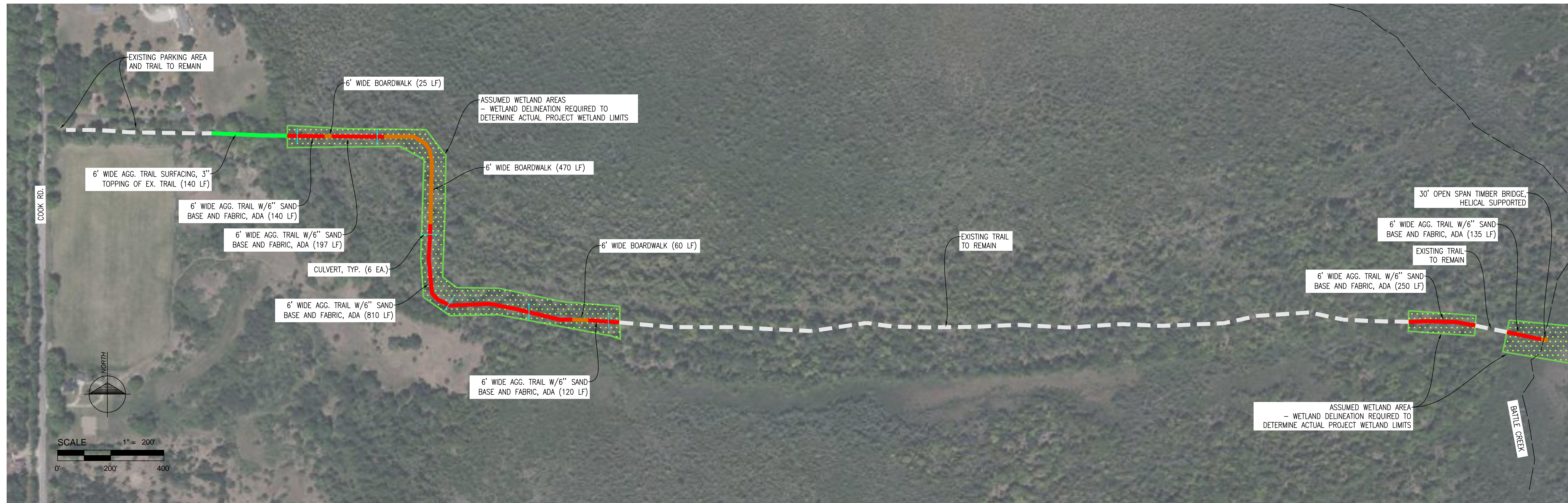

OVERALL CONCEPTUAL TRAIL IMPROVEMENTS

SCALE: 1" = 200'

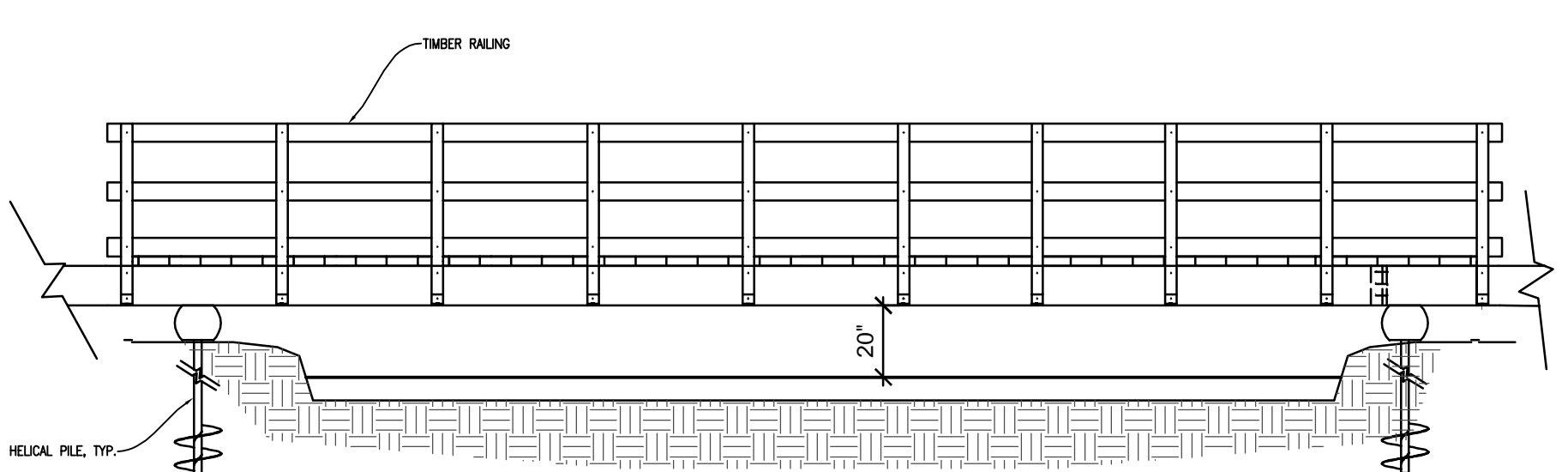
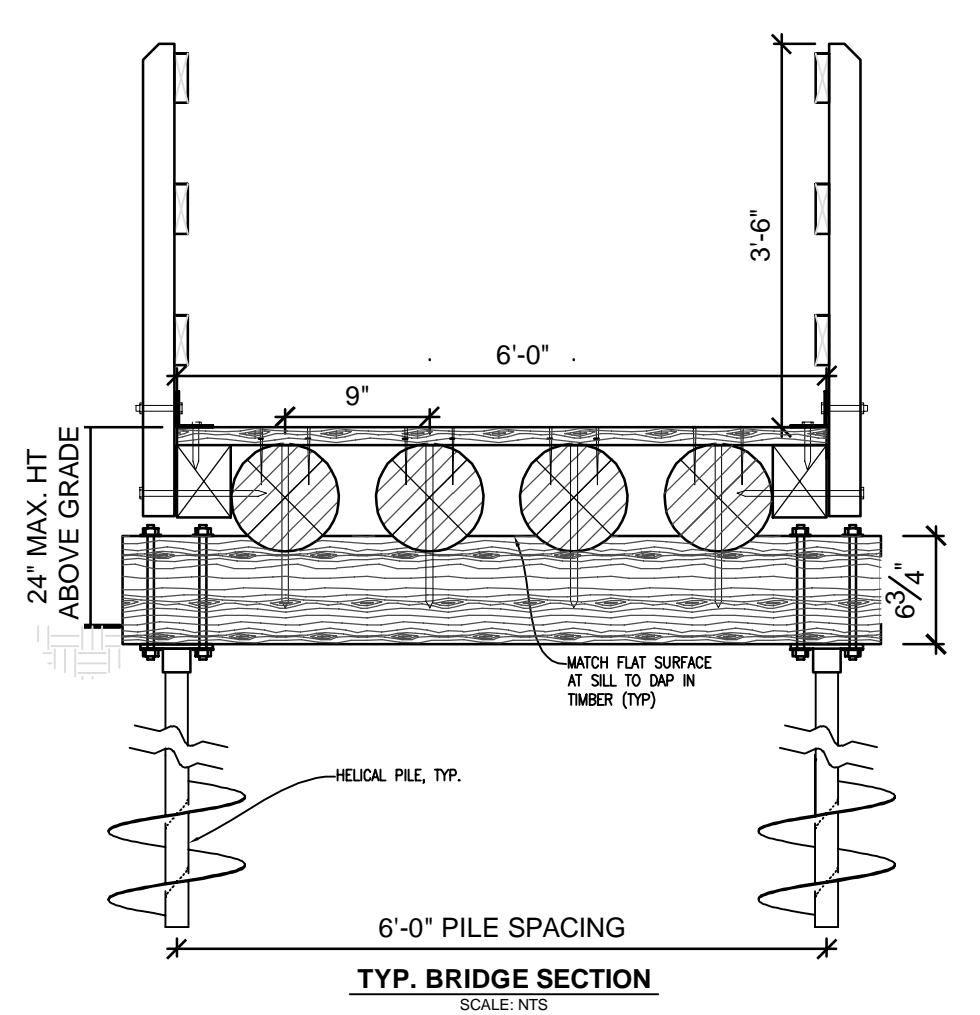
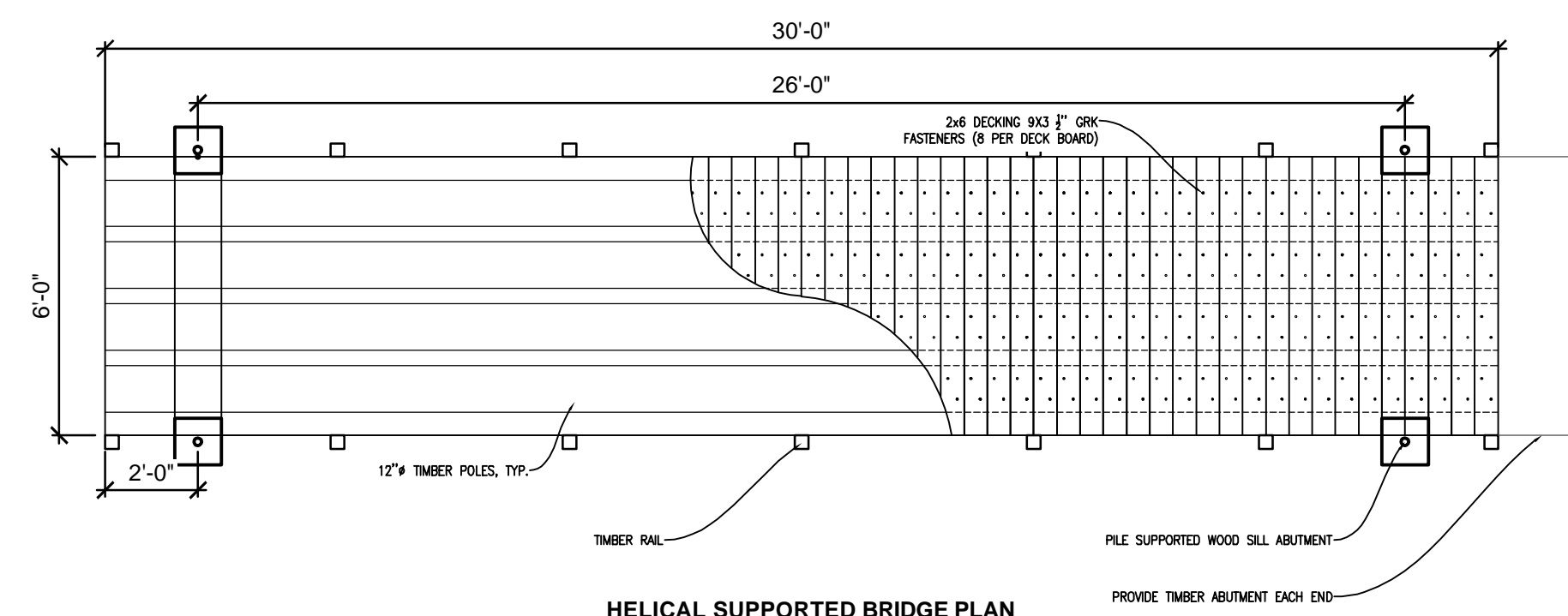
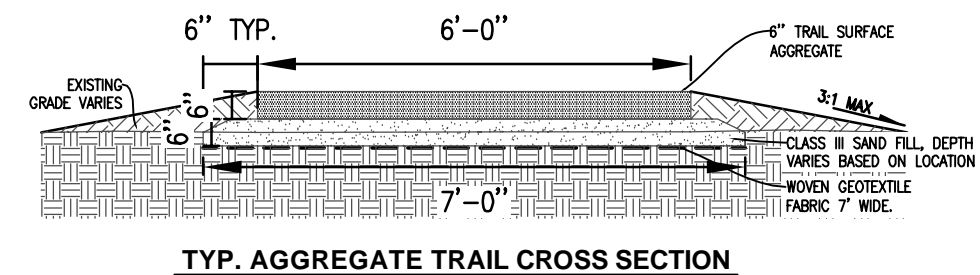

TIMBER FRAME BRIDGE DETAILS

SCALE: N.T.S.

NOTE: PREFABRICATED BRIDGE OPTION TO BE CONSIDERED

Lossier Trail Conceptual Cost Estimate					
Item	Qty	Unit	Unit Price	Cost	Notes
General Conditions and Mobilization	1	Ls	\$5,000.00	\$5,000.00	
Soil Erosion and Sedimentation Control	1	Ls	\$2,000.00	\$2,000.00	
6" Agg. Pathway w/6" Sand Fill Base & Fabric	1650	Lf	\$43.46	\$71,709.00	
6" Boardwalk (modified form 2023 GTCD Estimate)	575	Lf	\$150.00	\$86,250.00	Could be \$220/LF if contractor bid (not sure of structural capabilities), \$330/LF prefabricated system (structural), \$85/LF Youthworks.
Boardwalk Abutments	6	Ea	\$800.00	\$4,800.00	
Earthwork and Grading	1	Ls	\$5,000.00	\$5,000.00	Includes swamp mats for access
Culvert	6	Ea	\$1,000.00	\$6,000.00	
Restoration and Establishment	1	Ls	\$2,500.00	\$2,500.00	
Subtotal				\$183,259.00	
Contingency (10%)				\$18,325.90	
Est. Engineering (Preliminary/Final, EGLE Permit, Bidding)				\$55,000.00	
Est. Engineering (Construction Administration)				\$10,000.00	
Est. Project Total				\$266,584.90	

Alternate #1				
30' Timber Bridge	1	Ls	\$50,000.00	\$50,000.00

* Costs do not include regular trail maintenance
 * Costs do not include wetland mitigation or floodplain fill mitigation if either are required by EGLE

CONCEPTUAL COST ESTIMATE

SCALE: N.T.S.

Wetland Impact Calcs	Length	Width	SF	Acre	Notes
2206 LF trail in wetland (agg and BW)	2206	6	13,236	0.30	0.33 Ac. Max impact allowed prior to wetland mitigation. Includes Agg. and Boardwalk within assumed wetlands. Wetland delineation would need to be performed to accurately determine impacts

Floodplain Impact/Fill Calcs	Length	Width	CF	CYD	Notes
1266 LF trail w/fill in wetlands	1266	6.5	8,229	304.78	300 Max Cy/fill allowed in floodplain. Does not include boardwalk material as fill Floodplain elevation would need to be established before accurate fill calcs could be determined

EST. WETLAND AND FLOODPLAIN IMPACT CALCULATIONS

SCALE: N.T.S.

No.	Date	Revision	By

**OVERALL CONCEPT LAYOUT
 LOSSIE TRAIL IMPROVEMENTS
 WHITEWATER TOWNSHIP**

Date Issued: 6/7/24
 Date Surveyed: N/A
 Designed By: KSK
 Drawn By: KSK
 Checked By: DAW
 Scale: AS NOTED

Original sheet size is 22x34
 Location:
 WHITEWATER TOWNSHIP
 GRAND TRAVERSE COUNTY
 MICHIGAN
 ###

Project Number:
 2023634001.00

Sheet:
C1